



Quality Seed And Grain Equipment

# Small Scale Air Screen Cleaner



- Ideal for Research Quantities, Parent Seed, Small Lots, Vegetable and Specialty Seed – Unit Featured: 3 x 36 x 24 – 1+1+1 (Screen Size = (3) @ 24” W x 36” L)
- Screen #1: Fixed Scalp; Screen #2: Scalp or Sift; Screen #3: Fixed Sift
- Easily Accessible Allowing Thorough Clean Out Between Lots
- Capacity: Approximately 25 to 40 Bushels/Hour -- .7 to 1 Metric Ton/hour
- In-feed/Pre and Bottom/Post Aspiration for Removing Fines and Light Material
- Optional Vibratory Feed Available for Gentle Handling and Uniform Flow
- All Motors (Feed, Eccentric, & (2) Fans) are VFD Controlled for optimum performance/adjustability and energy efficiency
- Illustrating the Typical “Stand Alone” status of this cleaner with Air/Dust Containment and Control Filter Bag Assembly
- Allows this Small Scale Unit to be Completely Self Contained and Operate Independently in Various Facility Floor Plans
- Incorporates Many of the Same Robust Design and Construction Features of our Large Scale Air Screen Cleaner Product Line



# Small Scale Air Screen Cleaner

## Typical Unit Diagram

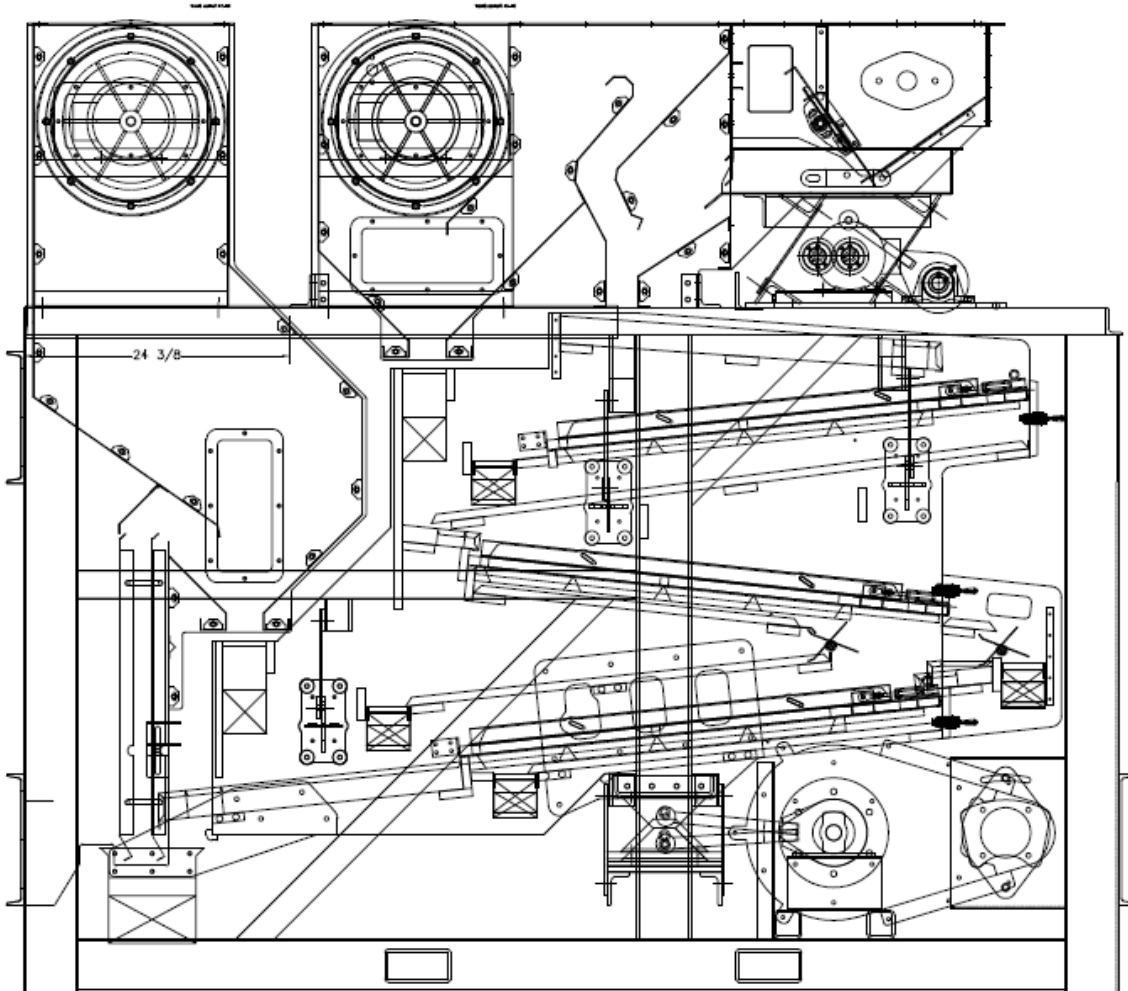

Q-SAGE 3x36-24-1+1+1  
SIDE VIEW  
LH MACHINE



Quality Seed And Grain Equipment