

PRODUCT GUIDE



PRECISION SORTING & INFINITE FLEXIBILITY

 **PROFILE**
INDUSTRIES

We manufacture innovative sorter technology to provide sorting solutions to a variety of global industries.



Seed &
Grain



Food



Hemp



Industrial



SORTING SOLUTIONS

Our line of innovative shape sorting technology will provide you with the purity and quality you need for your operation. With over 30 years of experience, we know one thing for sure. We succeed when you succeed, so lets get started.

We are committed to your success. Before, during and after the sale, we're here to bring customizable service to make this transition as easy and fluid as possible.

You won't have to wait for weeks while we construct your equipment; we build and maintain an inventory of our components and are able to configure and ship superior quality equipment to any customer, worldwide, within two days.

We also offer custom solutions, easy to learn equipment, and customer care from start to finish and beyond.



SEED QUALITY

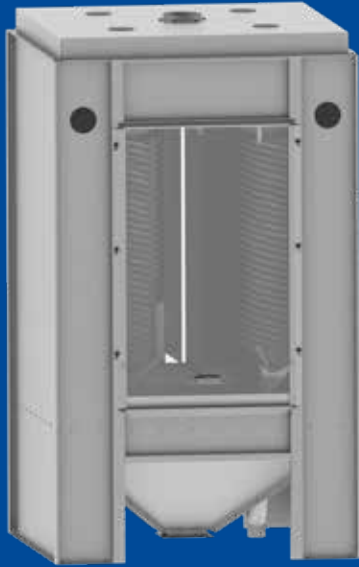

Our rotary technology not only gives you efficiency and flexibility, but the precision technology allows you to bag more good seed and improve product quality.

Used both, in agricultural and industrial industries, our rotary sorter will save you time and money by working to your unique operation.

It gives you the power to adjust to your own specific needs:

whether that's adjusting the variable sorter speed to fine tune your seed separation or giving you repeatability and uniformity for precise product classification to exceed industry requirements.

Resetting the rotary sorter is easier between seed lots with instant results at higher capacities taking the seed load of other machines.

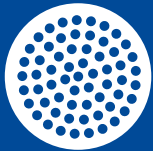

Screener



Rotary



Gravity Table



Color Sorter

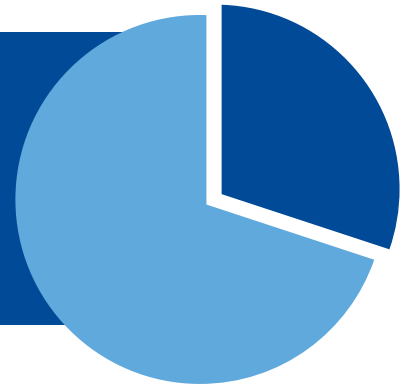

By incorporating the Rotary Sorter in their process, our clients have reduced seed loss by up to

30%

AT A GLANCE

- **High Capacity**

Available in configurations to meet sorting requirements

- **Replaceable Cores**

Maximum flexibility in sorting a variety of commodities

- **Observation Windows**

Provides visual monitoring of your products quality

- **Adjustable Flow Control**

Maximize sorting efficiency with precise metering

- **Variable Speed Control**

Simplifies adjusting separation of good seed from foreign material

- **Low Power Consumption**

Reduces operational costs

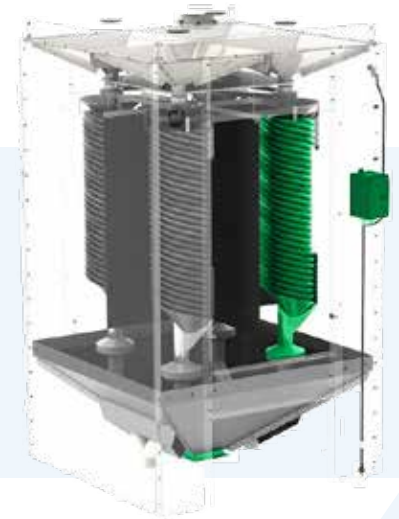

Input

115/208/230 VAC 60/50 Hz
*(optional 380/400/460/
575 VAC)*

Listed

UL / CE / CSA

Unit Dimensions

1c: 27" D 27" W 79" H
2c: 51" D 27" W 89" H
4c: 51" D 51" W 89" H

Capacity:

1c: 1.36 tonnes/hr
2c: 2.72 tonnes/hr
4c: 5.44 tonnes/hr



Soybeans



Mustard



Canola



Corn



Brassica



Hemp

The rotary sorters
have decreased
our total cleanout
7-15%, maybe more.
We appreciate
rotary sorters for
the easy adjustment
and the reduced
cleanout.

Semences C&S Daviau Inc.

3 Questions to Consider When Making Your Decision on New Machinery:

1. The Turnover of your seed conditioning Operators.

Do you often change operators, or are your operators there for a long-term employment?

2. The experience level of your seed conditioning operators.

Are they brand new?
Do they have years and years of experience?

3. The current quantity of seed conditioned.

What growth do you see for your facility in quantity and quality?

WHAT'S THE DIFFERENCE? SORTER VS. SEPARATOR

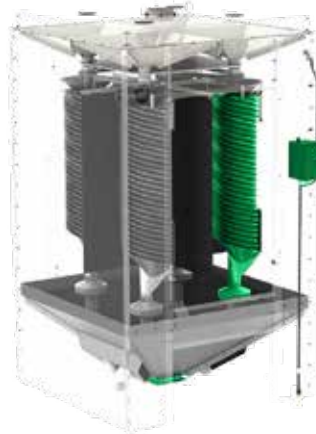

ROTARY SORTER

- ✓ Precision Sorting Technology
- ✓ VFD Rotating Cores
- ✓ Push Button PLC Flexibility



SPIRAL SEPARATOR

- Standard Separation
- Non-Power Based
- Manual Slide Gate Adjustment

NEED HELP DETERMINING THE BEST EQUIPMENT?

Send us a sample of your product and we'll run a free lab analysis to prove our machines do what we say they will do—sorting at its finest.

SPIRAL SEPARATORS



LAB SPIRAL SEPARATOR:

The heavy-duty Lab Spiral Separator is made for flexibility. With 5 different-sized inner flights ranging from 2-6", this machine can manage all of your seed separating needs and save you the space of 5 additional units.

Unit Dimensions

22"x22"x68"

Shipping Weight

250 lbs

Material

Galvanized steel

Power

None Required



OPEN SPIRAL SEPARATOR:

Portable and profitable. The Open Spiral easily separate good seed from splits, weed seed and chaffs based on their shape and size.

Dimensions

20"x20"x72"

Shipping Weight

250 lbs

Material

Galvanized Steel

Power

None Required



ENCLOSED SPIRAL SEPARATOR

The Enclosed Spiral Separator ensures durability due to its 14 to 16-gauge galvanized steel, and you can configure it from 1 to 24 core units. As your operation grows and changes, this product can as well.

Unit Dimensions

1c: 27" D 27" W 73" H

2c: 51" D 27" W 89" H

4c: 51" D 51" W 89" H

Material

Galvanized Steel

Power

None Required



Alfalfa



Peas



Peppercorn

Features

- 4 turns of separation
- Adjustable gate for fine-tuning separation quality
- XL observation windows
- Adjustable flow control
- Replaceable spiral cores
- Vertical no clog design
- Easy access to clean and sanitize
- Can be used mobile

Optional Features

- Stainless steel flights
- Stainless steel construction
- 14 unique flight geometries
- Discharge adapters
- Custom leg heights
- Powder coated custom colors
- Rubber lined floor and walls
- Horizontal round material discharge

SORTERS



BELT GRADER

The Belt Grader helps to ensure that there's no cross contamination when processing products. Due to its open, flat belt design, the Belt Grader can sort round material from non-round material, and rough surfaces from smooth surfaces.

Unit Dimensions

36"X42"X70

Shipping Weight

450 lbs

Material

Aluminum

Input

115 VAC 60 Hz
(optional 230 VAC 60/50 Hz)

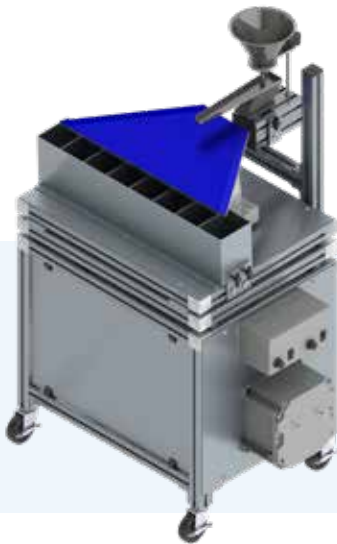

OSCILLATING SHAPE SORTER

Due to its interchangeable decks offering different textures, the Oscillating Shape Sorter can accommodate a wide range of seed separations.

Dimensions

32"x24"x48"

Shipping Weight

320 lbs

Material

Aluminum with abrasive deck

Input:

115 VAC 60 Hz
(optional 230 VAC 60/50 Hz)

The Oscillating Sorter has been very consistent and seems to be built to last! We have been able to produce a more consistent product in a more timely manner.

MO-SCI Corporation

CUSTOMER CARE

/// Canada

/// USA

/// Germany

/// Brazil

/// Argentina

New Zealand ///

/// Local Support & Application Centers

If there's one thing we know that everyone wants from their seed machinery, it's precise cleaning and sorting. If your current machine isn't doing the job, then it's time to find another solution to your problem.

Profile-Ind.com

 **PROFILE**
INDUSTRIES

f t y v in G+